

XMC247

**XMC QUAD 10GbE
BASE-T and Optics options
I/O Front or XMC Rear**



XMC247

Key Features

- Quad 10GbE with PCIe x8 Gen3
- BASE-T (100BASE-TX, 1G/2.5G/5G/10GBASE-T)
- Quad 10GbE configuration ordering option as:
 - Quad BASE-T (front I/O)
 - Quad BASE-T (XMC rear I/O)
 - Dual BASE-T (front I/O) and Dual Optical (front I/O)
 - Dual BASE-T (front I/O) and 10GBASE-KR (XMC rear I/O)
- Utilizing Intel X710-TM4 MAC/PHY

Benefits

- Design utilizes proven VadaTech subcomponents and engineering techniques
- Electrical, mechanical, software, and system-level expertise in house
- Full system supply from industry leader
- AS9100 and ISO9001 certified company



vadatech
THE POWER OF VISION



XMC247

The XMC247 has Quad 10GbE interface to the host via PCIe x8 Gen3. Ordering option supports flexible I/O routing to the front and/or to the rear of the XMC I/O connector, including support for the front-panel optics.

The module BASE-T is defined as 100BASE-TX, 1G/2.5G/5G/10GBASE-T. The XMC247 has the following configuration options:

- Dual BASE-T (front I/O) with Dual Optics (front I/O)
- Dual BASE-T (front I/O) with Dual 10GBASE-KR (XMC rear I/O)
- Quad BASE-T (front I/O)
- Quad BASE-T (XMC rear I/O)

See figures below for details.

The module is available in both air cooled and conduction cooled versions.



Figure A: XMC247 A=0

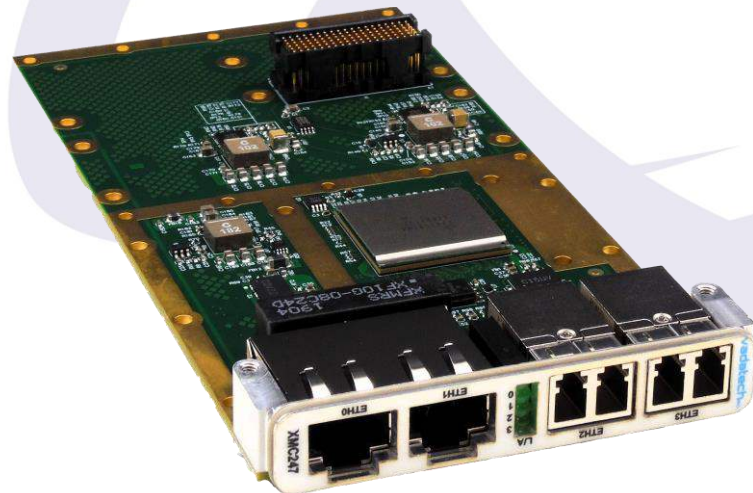

Figure B: XMC247 A=0 without Heatsink

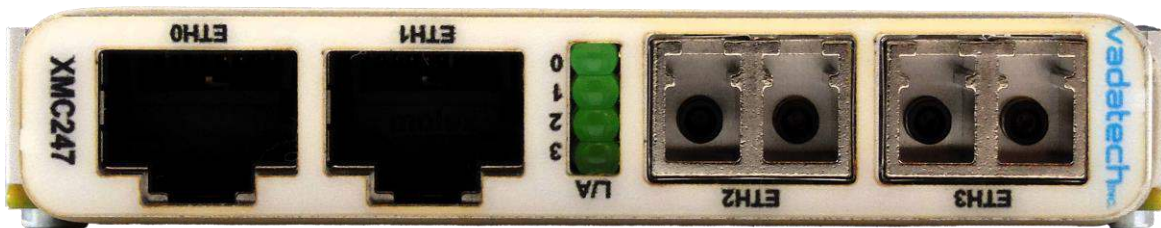

Figure C: XMC247 A=0 Front Panel View

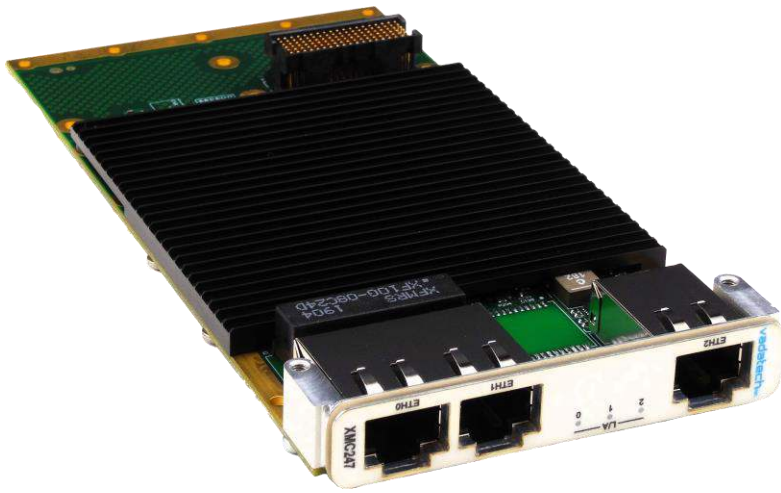

Figure D: XMC247 A=2

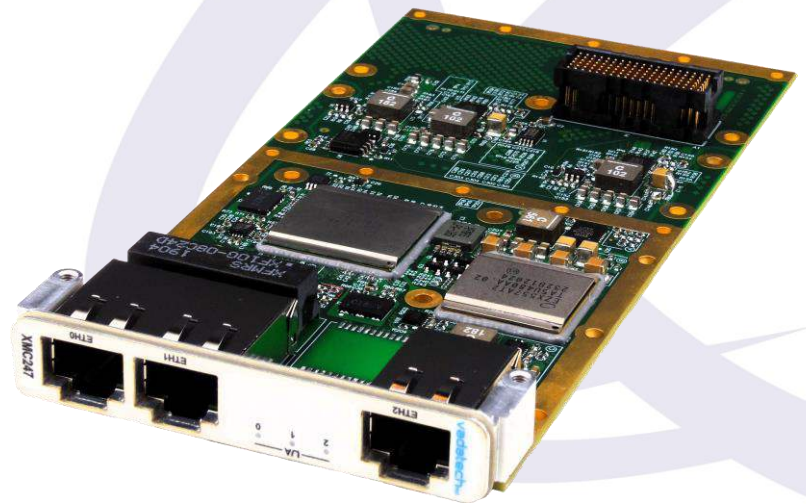

Figure E: XMC247 A=2 without Heatsink

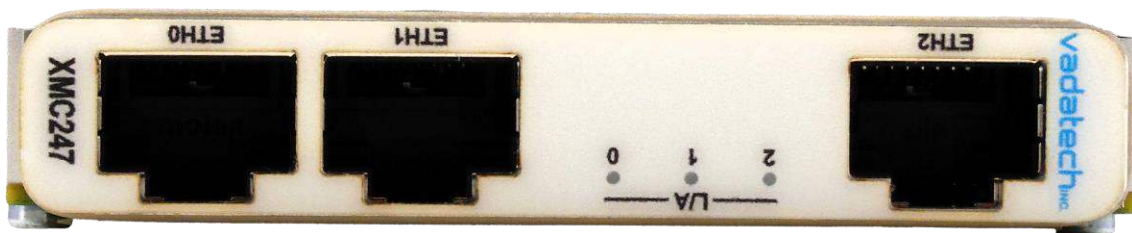

Figure F: XMC247 A=2 Front Panel View

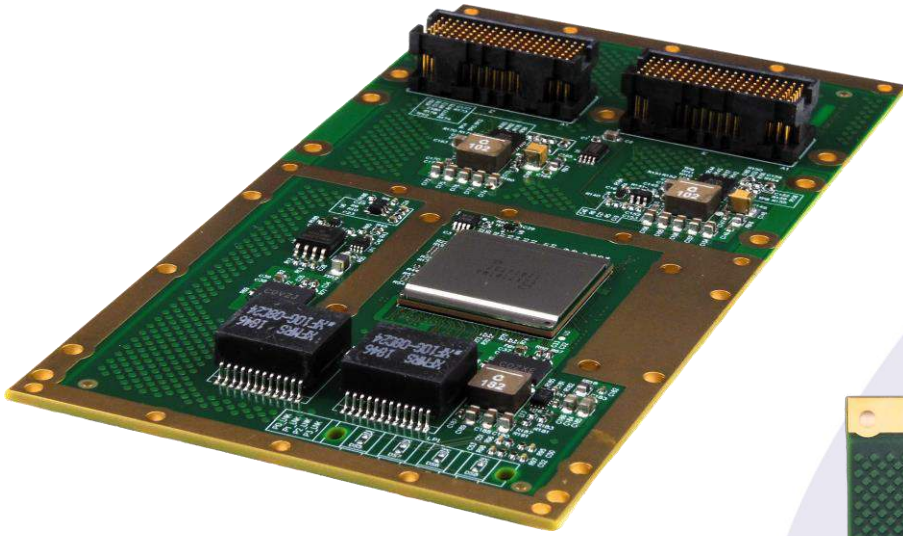

Figure G: XMC247 A=4

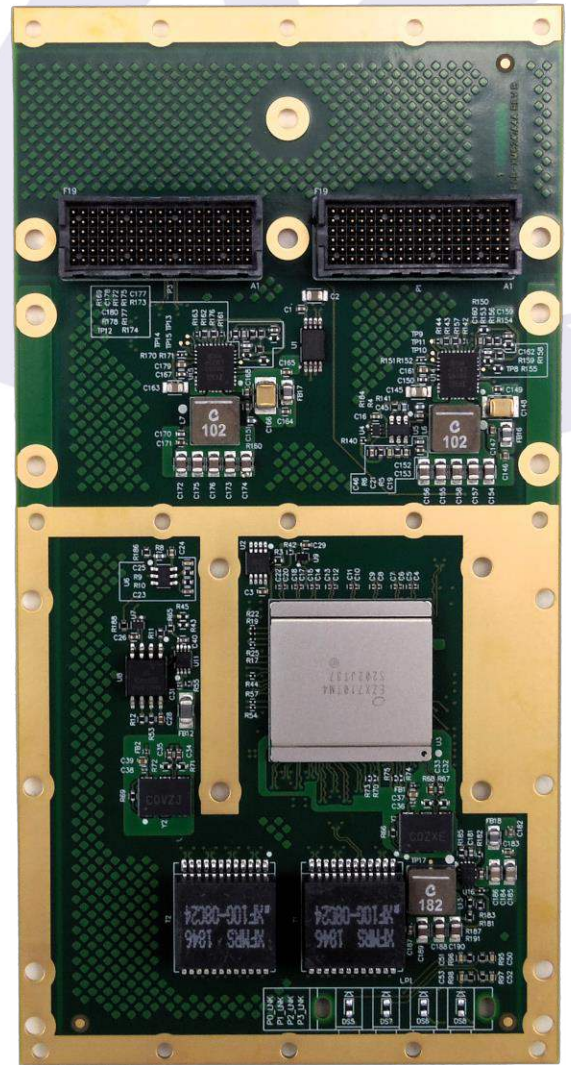

Figure H: XMC247 A=4 Top View



Figure I: XMC247 A=1



Figure J: XMC247 A=6

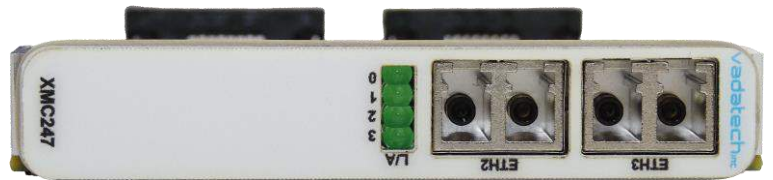

Figure K: XMC247 A=6 Front Panel View

Block Diagram

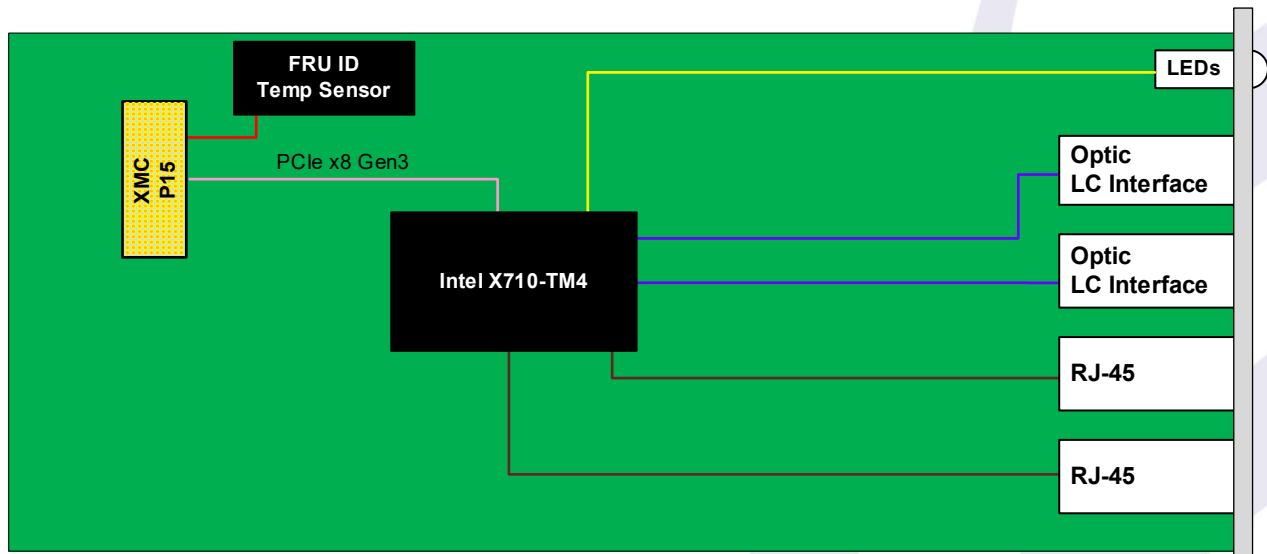

Figure 1: Functional block diagram (Dual 10GBASE-T and Dual Optics 10G front I/O)

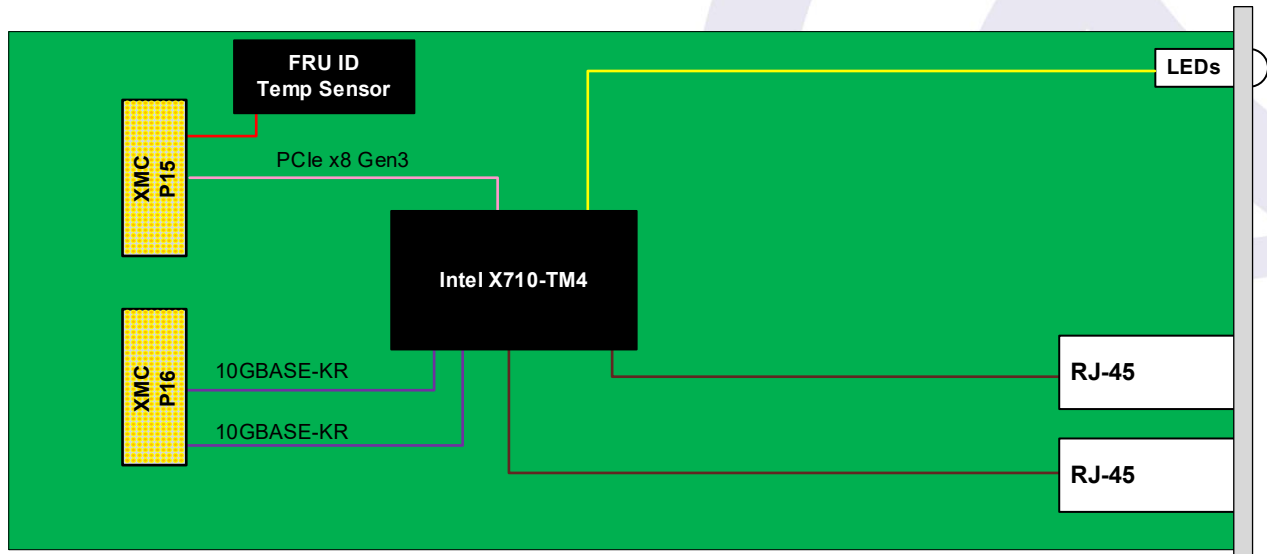

Figure 2: Functional block diagram (Dual 10GBASE-T front I/O and Dual 10GBASE-KR rear I/O)

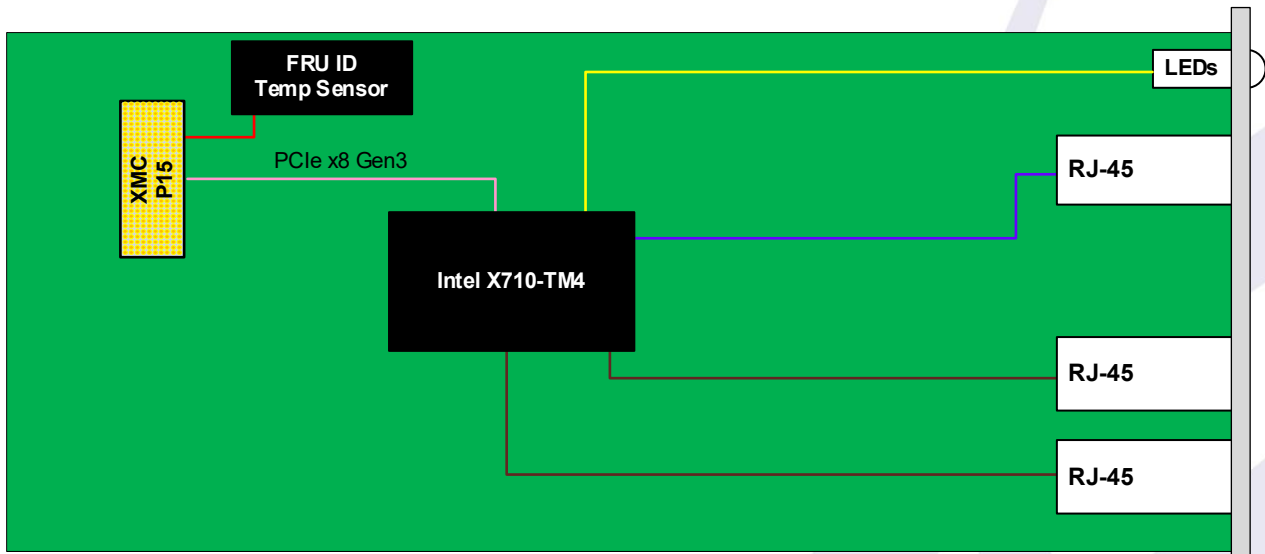

Figure 3: Functional block diagram (Triple 10GBASE-T front I/O) **No longer supported, consider XMC249 Product**

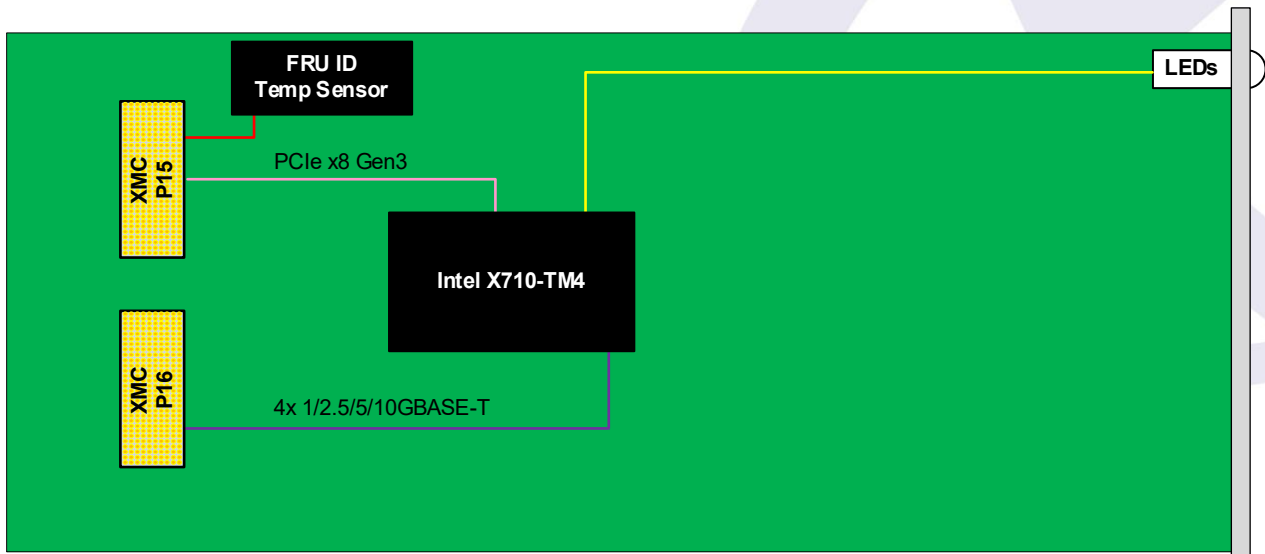

Figure 4: Functional block diagram (Quad 10GBASE-T rear I/O) **No longer supported, consider XMC249 Product**

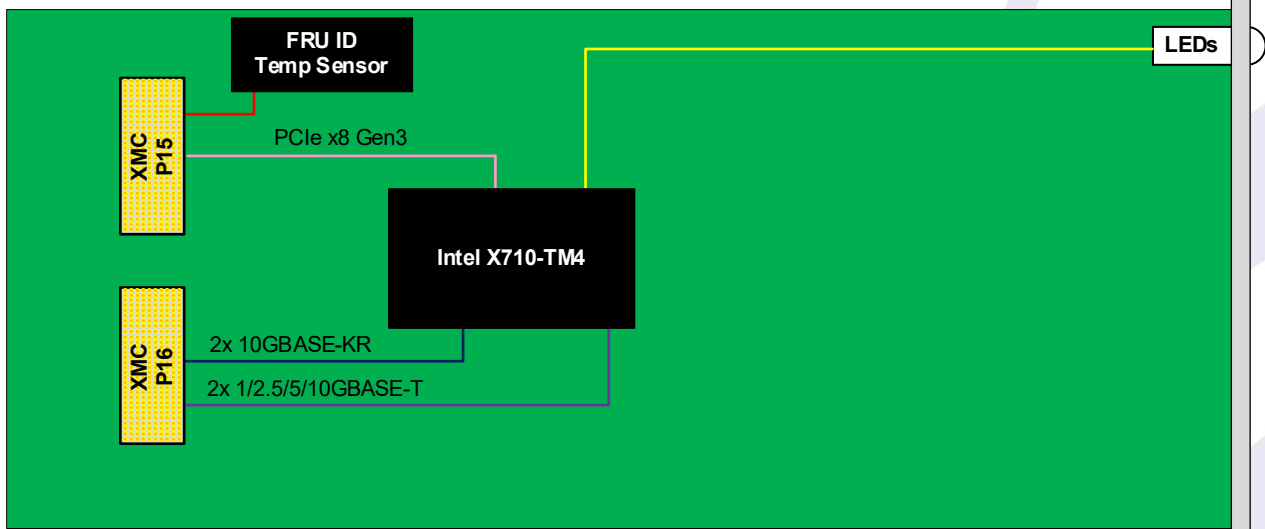

Figure 5: Functional block diagram (Dual 10GBASE-T and Dual 10GBASE-KR rear I/O)

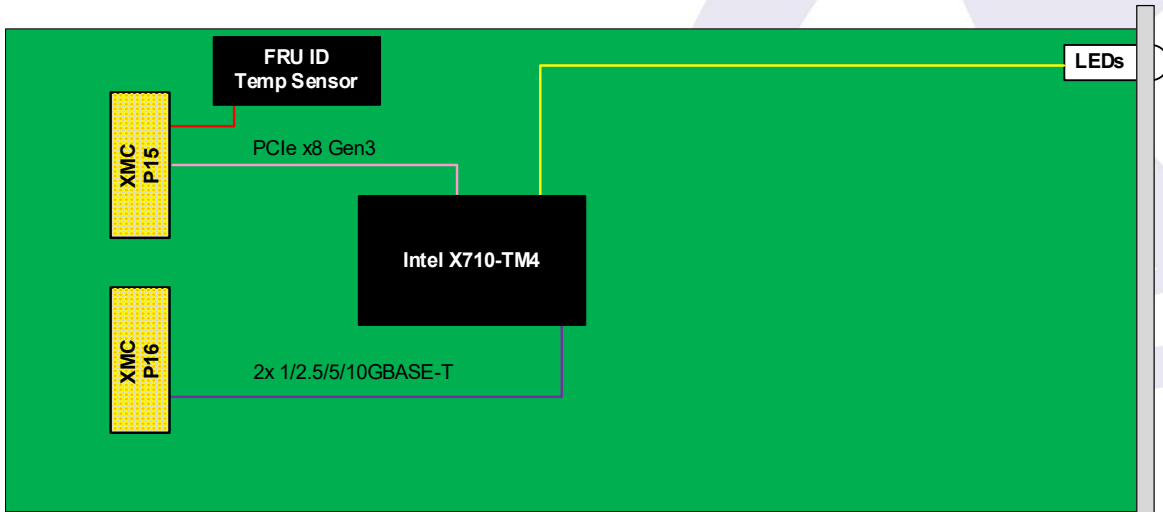

Figure 6: Functional block diagram (Dual 10GBASE-T rear I/O)

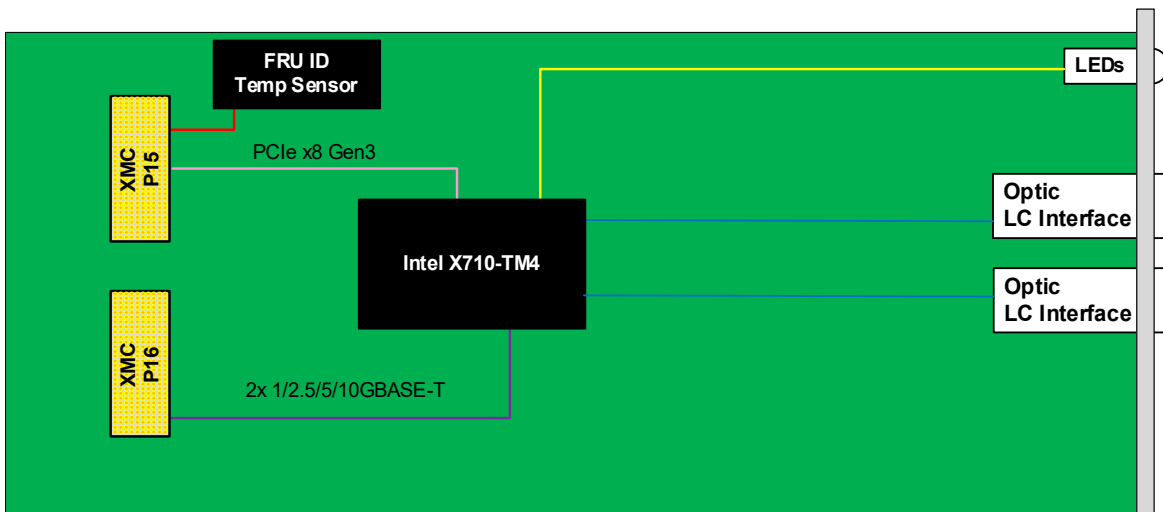

Figure 7: Functional block diagram (Dual 10GBASE-T rear I/O with Dual 10G Optics in the front)

Specifications

Architecture	
Physical	Dimensions Single-Width, per VITA 42.0 specification
Type	XMC 10GbE 4 Port 10GbE
Standards	
XMC	Type 10GbE
Module Management	Sensors FRU info and Temp sensor
Configuration	
Power	XMC247 14W with Dual 10GBASE-T and Dual Optics; 17W with Quad 10GBASE-T
Environmental	Temperature See Ordering Options and Environmental Spec Sheet
Front Panel	Interface Connectors Ordering option dependent
	LEDs LNK/ACT
Software Support	Operating System Linux, Windows and VxWorks
Other	
MTBF	MIL Hand book 217-F@ TBD hrs
Certifications	Designed to meet FCC, CE and UL certifications, where applicable
Standards	VadaTech is certified to both the ISO9001:2015 and AS9100D standards
Warranty	Two (2) years, see VadaTech Terms and Conditions

INTEGRATION SERVICES AND APPLICATION-READY PLATFORMS

VadaTech has a full ecosystem of OpenVPX, ATCA and MTCA products including chassis platforms, shelf managers, AMC modules, Switch and Payload Boards, Rear Transition Modules (RTMs), Power Modules, and more. The company also offers integration services as well as pre-configured Application-Ready Platforms. Please contact VadaTech Sales for more information.

Ordering Options

XMC247 – AB0-000-0HJ

A = Quad Port routing option 0 = Per figure 1 1 = Per figure 2 2 = Per figure 3 (only three ports) * 3 = Per figure 4 * 4 = Per figure 5 5 = Per figure 6 6 = Per figure 7		
B = XMC Connectors 0 = VITA 42 1 = VITA 61		H = Environmental See Environmental Specification
		J = Conformal Coating 0 = No coating 1 = Humiseal 1A33 Polyurethane 2 = Humiseal 1B31 Acrylic

*Note: These options are no longer supported by the XMC247, please consider XMC249

Environmental Specification

Option H	Air Cooled			Conduction Cooled		
	H = 0	H = 1	H = 2	H = 3	H = 4	
Operating Temperature	AC1* (0°C to +55°C)	AC3* (-40°C to +70°C)	CC1* (0°C to +55°C)	CC3* (-40°C to +70°C)	CC4* (-40°C to +85°C)	
Storage Temperature	C1* (-40°C to +85°C)	C3* (-50°C to +100°C)	C1* (-40°C to +85°C)	C3* (-50°C to +100°C)	C3* (-50°C to +100°C)	
Operating Vibration	V2* (0.04 g2/Hz max)	V2* (0.04 g2/Hz max)	V3* (0.1 g2/Hz max)	V3* (0.1 g2/Hz max)	V3 (0.1 g2/Hz max)	
Storage Vibration	OS1* (20g)	OS1* (20g)	OS2* (40g)	OS2* (40g)	OS2* (40g)	
Humidity	95% non-condensing	95% non-condensing	95% non-condensing	95% non-condensing	95% non-condensing	

Notes:

*Nomenclature per ANSI/VITA 47. Contact local sales office for conduction cooled (H = 2, 3, 4).

Related Products

VPX762



- 6U VPX module Xeon-D SoC (Skylake-D) 6th-Generation
- Single XMC site with I/O expansion going to P5/P6 per VITA46.9 Pin Field P5W1-P64s+X12d+X8d
- PCIe Gen3 x16 (bifurcation to Dual x8 or Quad x4)

VPX752



- 6U VPX module Intel 5th Generation Xeon-D SoC
- Single XMC site with I/O expansion going to P5/P6
- PCIe Gen3 x16 (Dual x8 or Quad x4)

VPX105



- 6U VPX module VITA 46.0 for Dual PMC/XMC modules
- PCIe x8 to each XMC
- The XMC connector option with VITA 42.0 or VITA 61.0

Contact

VadaTech Corporate Office

198 N. Gibson Road, Henderson, NV 89014

Phone: +1 702 896-3337 | Fax: +1 702 896-0332

Asia Pacific Sales Office

7 Floor, No. 2, Wenhua Street, Neihu District, Taipei 114, Taiwan

Phone: +886-2-2627-7655 | Fax: +886-2-2627-7792

VadaTech European Sales Office

VadaTech House, Bulls Copse Road, Southampton, SO40 9LR

Phone: +44 2380 016403

info@vadatech.com | www.vadatech.com

Choose VadaTech

We are technology leaders

- First-to-market silicon
- Constant innovation
- Open systems expertise

We commit to our customers

- Partnerships power innovation
- Collaborative approach
- Mutual success

We deliver complexity

- Complete signal chain
- System management
- Configurable solutions

We manufacture in-house

- Agile production
- Accelerated deployment
- AS9100 accredited



vadatech
THE POWER OF VISION

Trademarks and Disclaimer

The VadaTech logo is a registered trademark of VadaTech, Inc. Other registered trademarks are the property of their respective owners. AdvancedTCA™ and the AdvancedMC™ logo are trademarks of the PCI Industrial Computers Manufacturers Group. All rights reserved. Specification subject to change without notice.

© 2020 VadaTech Incorporated. All rights reserved.
DOC NO. 4FM737-12 REV 01 | VERSION 1.1 – SEP/25